

PC2H single point load cell

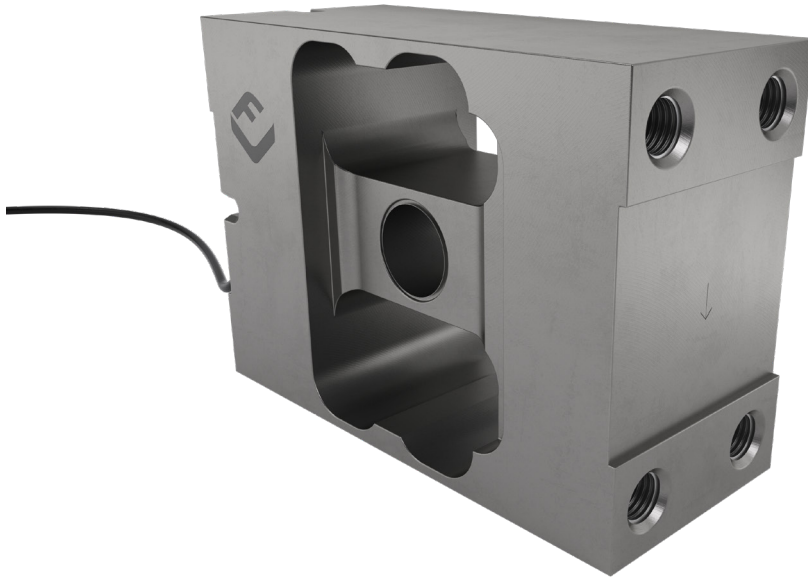

product description

The PC2H is designed for front-end and rear-end bin lifting systems on waste collection vehicles. Certified by OIML, the PC2H is the ideal choice for trade approved waste collection applications. The fully welded, stainless steel design and rugged construction overcomes the problems associated with alternative aluminium load cell based systems.

Alternative load cell size and bolt hole configurations are available in the Flintec bin-lift load cell range; see the PC3H, PC5H, PC6H and PC7H single point load cells.

applications

Front end (FEL) and rear end (REL) bin lifting systems for waste collection vehicles (RCV's).

options

Y = 20,000 for C3

accessories

Compatible range of electronics

key features

Capacity of 2,000kg

Stainless steel construction with a bead blasted surface

Hermetically sealed to IP68/IP69K

Rugged construction with side mounting

Off-centre load adjusted

High accuracy

For platform sizes of up to 1,200 x 1,200mm

approvals

OIML approval to C3 (Y = 10,000)

ATEX hazardous area approval for zones 0, 1, 2, 20, 21 and 22



RoHS
compliant



specifications

Maximum capacity (E_{max})	kg	2,000	
Accuracy class according to OIML R60	-	(GP)	C3
Maximum number of verification intervals (n_{LC})	-	n.a.	3,000
Minimum load cell verification interval (v_{min})	-	n.a.	$E_{max} / 10,000$
Temperature effect on minimum dead load output (TC_0)	%*RO/10°C	± 0.0400	± 0.0140
Temperature effect on sensitivity (TC_{RO})	%*RO/10°C	± 0.0200	± 0.0100
Combined error	%*RO	± 0.0500	± 0.0200
Non-linearity	%*RO	± 0.0400	± 0.0166
Hysteresis	%*RO	± 0.0400	± 0.0166
Creep error (30 minutes) / DR	%*RO	± 0.0600	± 0.0166
Optional: Min. load cell verification interval ($v_{min opt}$)	-	n.a.	$E_{max} / 20,000$
Optional: Temp. effect on min. dead load output ($TC_0 opt$)	%*RO/10°C	n.a.	± 0.0070
Rated Output (RO)	mV/V	2 ± 5%	
Calibration in mV/V/Ω	%		
Zero balance	%*RO	± 5	
Excitation voltage	V	5...15	
Input resistance (R_{LC})	Ω	1,100 ± 50	
Output resistance (R_{out})	Ω	960 ± 50	
Insulation resistance (100 V DC)	MΩ	≥ 5,000	
Safe load limit (E_{lim})	%* E_{max}	200	
Ultimate load	%* E_{max}	300	
Safe side load	%* E_{max}	100	
Maximum off centre loading effect	%*RO/mm	± 0.00002	
Maximum off centre distance at maximum capacity	mm	175	
Compensated temperature range	°C	-10...+40	
Operating temperature range	°C	-40...+80 (ATEX -40...+60)	
Load cell material	-	stainless steel 17-4 PH (1.4548)	
Sealing	-	complete hermetic sealing; cable entry sealed by glass to metal header	
Protection according EN 60 529	-	IP68 (up to 2m water depth) / IP69K	
Packet weight	kg	8.3	

The limits for Non-Linearity, Hysteresis, and TC_{RO} are typical values.

The sum of Non-linearity, Hysteresis and TC_{RO} meets the requirements according to OIML R60 with $p_{LC}=0.7$.



product dimensions (mm)

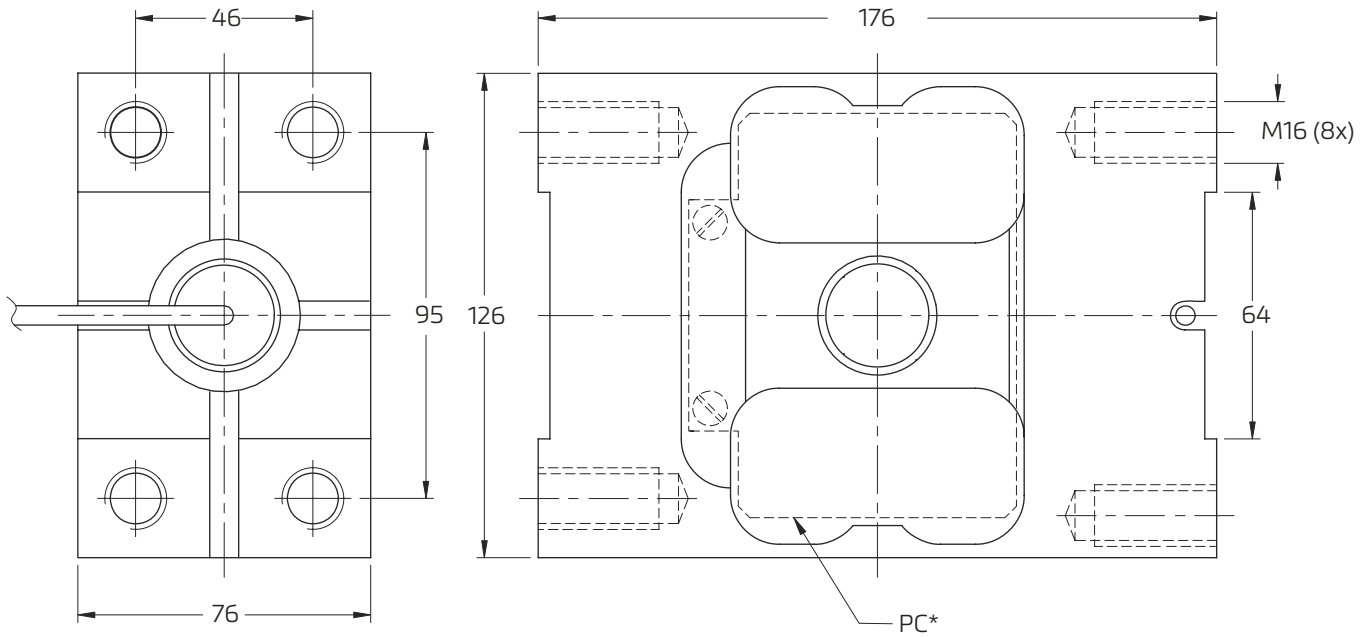

Mounting bolts M16 8.8; torque 200 Nm. Torque value assumes oiled threads.

PC* - Protective cover available on request. 6mm thick, two sides.

wiring

The load cell is provided with a shielded, 6 conductor cable (AWG 26).

Cable jacket: polyurethane

Cable length: 5 m

Cable diameter: 5.8 mm

The shield is floating or connected to the load cell body

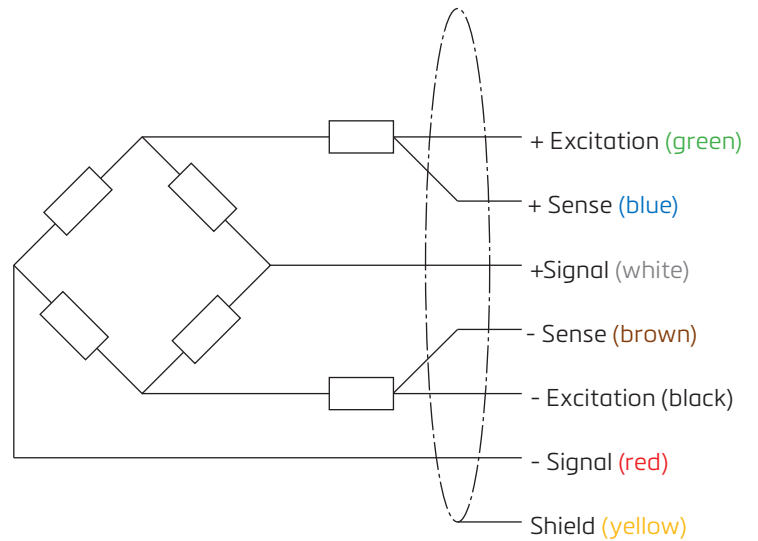

Specifications and dimensions are subject to change without notice.