

PC81 single point load cell

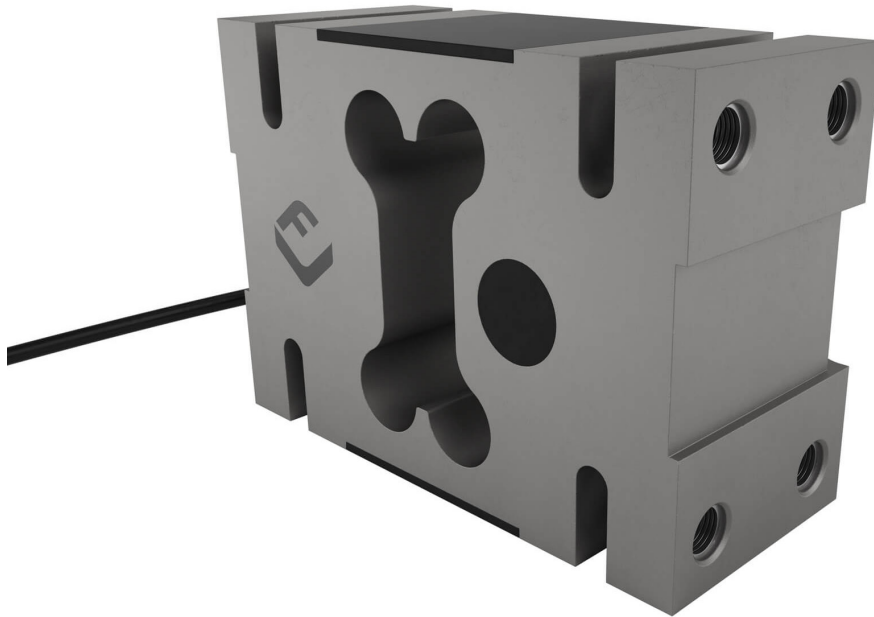

product description

The PC81 is a high capacity, single point load cell designed for the manufacture of very large platform scales up to 1.4 x 1.4m. The large side located mounting threads the PC81 can also be used in vessel and hopper weighing applications and bin-lifting applications in the field of on-board vehicle weighing. Constructed from aluminium and environmentally sealed with potting compound to ensure durability.

applications

Platform scales, vessel and hopper weighing, bin-lift systems.

key features

Aluminium construction

Environmentally sealed by potting to IP67

High capacity of 2,000kg

For platform sizes of up to 1400 x 1400mm

Side mount, rugged design with low sensitivity to moment

accessories

Compatible range of electronics



RoHS
compliant



specifications

Maximum capacity (E_{max})	kg	2,000	
Accuracy class		GP	G3*
Temperature effect on minimum dead load output (TC_0)	%*RO/10°C	± 0.0400	± 0.0230
Temperature effect on sensitivity (TC_{RO})	%*RO/10°C	± 0.0200	± 0.0100
Combined error	%*RO	± 0.0500	± 0.0200
Non-linearity	%*RO	± 0.0400	± 0.0166
Hysteresis	%*RO	± 0.0400	± 0.0166
Creep error (30 minutes) / DR	%*RO	± 0.0600	± 0.0166
Rated Output (RO)	mV/V	2 ± 10%	
Zero balance	%*RO	± 10	
Excitation voltage	V	5...15	
Input resistance (R_{LC})	Ω	410 ± 15	
Output resistance (R_{out})	Ω	350 ± 3	
Insulation resistance (100 V DC)	MΩ	≥ 5,000	
Safe load limit (E_{lim})	%* E_{max}	150	
Ultimate load	%* E_{max}	300	
Safe side load	%* E_{max}	100	
Maximum platform size	mm	1,400 x 1,400	
Maximum off centre distance at maximum capacity	mm	175	
Compensated temperature range	°C	-10...+40	
Operating temperature range	°C	-30...+70	
Load cell material		aluminium	
Sealing		potted	
Protection according EN 60 529		IP67	
Packet weight	kg	4.0	

* corresponds to C3 quality, test certificate not available

The limits for Non-Linearity, Hysteresis, and TC_{RO} are typical values.

The sum of Non-linearity, Hysteresis and TC_{RO} meets the requirements according to OIML R60 with $p_{LC}=0.7$.



product dimensions (mm)

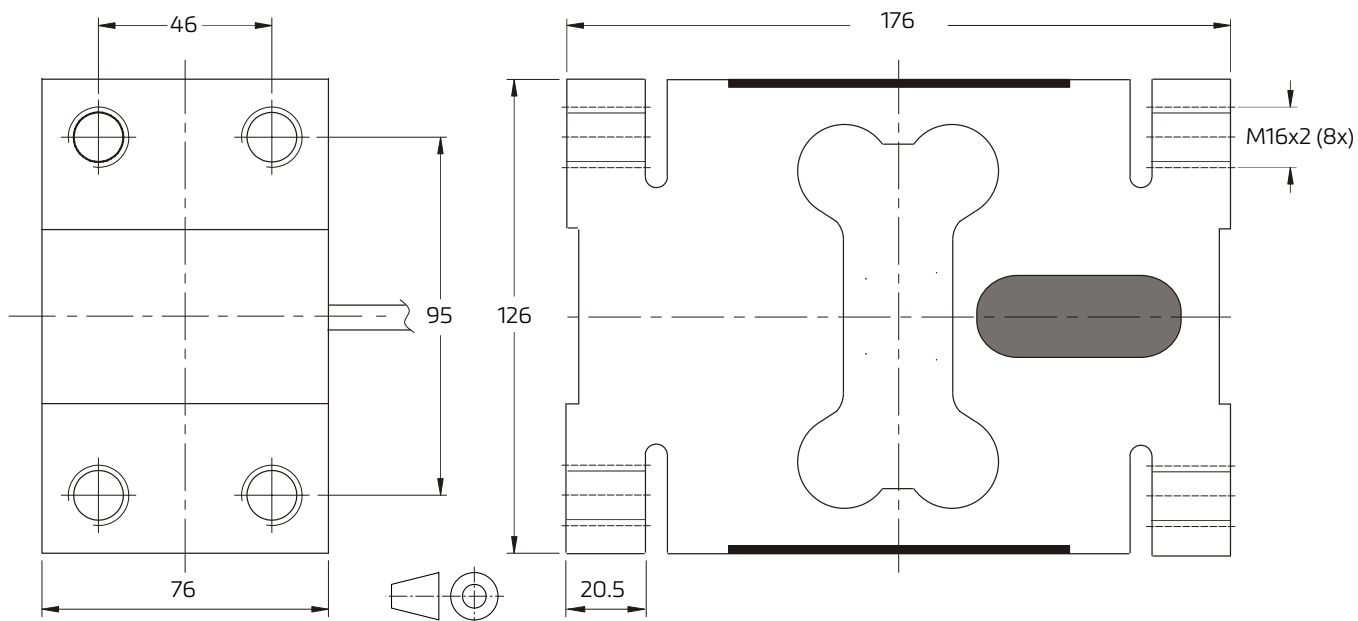

Mounting bolts M16x2; torque 200 Nm. Torque value assumes oiled threads.

wiring

The load cell is provided with a shielded 6 conductor cable (AWG 26).

Cable jacket: polyurethane

Cable length: 6 m

Cable diameter: 5.8 mm

The shield is connected to the load cell body

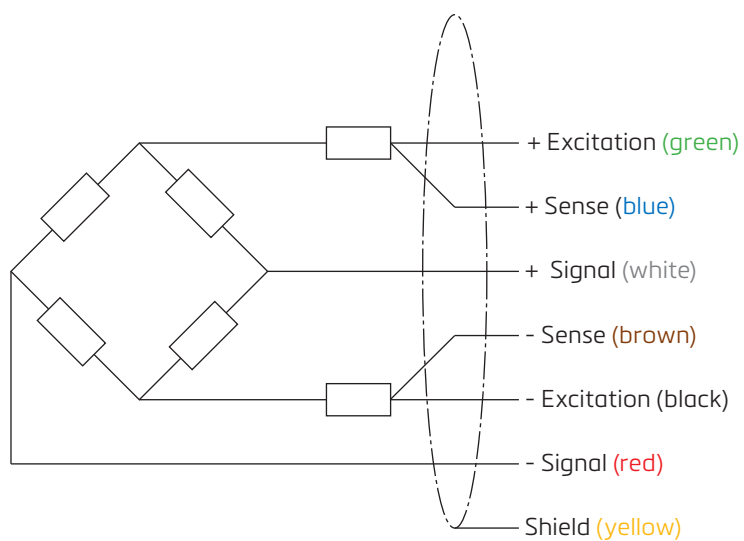

Specifications and dimensions are subject to change without notice.