

UB6 tension load cell



product description

A low capacity, fully welded, stainless steel tension and compression load cell. The UB6 is designed for space constrained applications where robustness is still an important consideration. Available in a range of capacities from 75kg through to 500kg it is particularly suited for high accuracy Process Weighing applications. Certified by both OIML and NTEP for trade approved weighing.

applications

Suspended tanks and hoppers, crane scales.

key features

Stainless steel construction

Hermetically sealed to IP68

Capacity range from 0.7kN to 5kN (75kg to 510 kg)

Tension and compression loading

High accuracy

High input resistance

Calibration in mV/V/ Ω

approvals

OIML approval to C3 (Y = 10,200)

NTEP approval to 5,000 intervals, Class III and 10,000 intervals, Class III L

ATEX hazardous area approval for zones 0, 1, 2, 20, 21 and 22

FM hazardous area approval

accessories

Compatible range of hardware

Compatible range of electronics

options

Y = 20,400 for C3

Stainless steel cable gland



RoHS compliant



 **flintec**
quality + precision

specifications

Maximum capacity (E_{max})	kN	0.7 / 1 / 2 / 5		
Metric equivalents (1 N=0.10197 kg)	kg	75 / 102 / 204 / 510		
Minimum capacity (E_{min})	$\%*E_{max}$	0		
Accuracy class according to OIML R60		(GP)	C1	C3
Maximum number of verification intervals (n_{max})		n.a.	1,000	3,000
Minimum load cell verification interval (v_{min})		n.a.	$E_{max}/5,100$	$E_{max} / 10,200$
Temperature effect on minimum dead load output (TC_0)	$\%*RO/10^{\circ}C$	± 0.0400	± 0.0275	± 0.0137
Temperature effect on sensitivity (TC_{RO})	$\%*RO/10^{\circ}C$	± 0.0200	± 0.0160	± 0.0100
Combined error	$\%*RO$	± 0.0500	± 0.0300	± 0.0200
Non-linearity	$\%*RO$	± 0.0400	± 0.0300	± 0.0166
Hysteresis	$\%*RO$	± 0.0400	± 0.0300	± 0.0166
Creep error (30 minutes) / DR	$\%*RO$	± 0.0600	± 0.0490	± 0.0166
Option: Min. load cell verification interval ($v_{min\ opt}$)		n.a.	n.a.	$E_{max} / 20,400$
Option: Temp. effect on min. dead load output ($TC_0\ opt$)	$\%*RO/10^{\circ}C$	n.a.	n.a.	± 0.0069
Rated Output (RO)	mV/V	$2 \pm 0.1\%$		
Calibration in mV/V/ Ω (A...I classified)	%	$\pm 0.05 (\pm 0.005)$		
Zero balance	$\%*RO$	± 5		
Excitation voltage	V	5...15		
Input resistance (R_{LC})	Ω	$1,100 \pm 50$		
Output resistance (R_{out})	Ω	$1,000 \pm 2$		
Insulation resistance (100 V DC)	M Ω	$\geq 5,000$		
Safe load limit (E_{lim})	$\%*E_{max}$	200		
Ultimate load	$\%*E_{max}$	300		
Compensated temperature range	$^{\circ}C$	-10...+40		
Operating temperature range	$^{\circ}C$	-40...+80 (ATEX -40...+60)		
Load cell material		stainless steel 17-4 PH (1.4548)		
Sealing		complete hermetic sealing; cable entry sealed by glass to metal header		
Protection according EN 60 529		IP68 (up to 2 m water depth) / IP69K		
Packet weight	kg	1.0 (1kN, 2 kN), 1.1 (5kN)		

The limits for Non-Linearity, Hysteresis, and TC_{RO} are typical values.

The sum of Non-linearity, Hysteresis and TC_{RO} meets the requirements according to OIML R60 with $p_{LC}=0.7$.



product dimensions (mm)

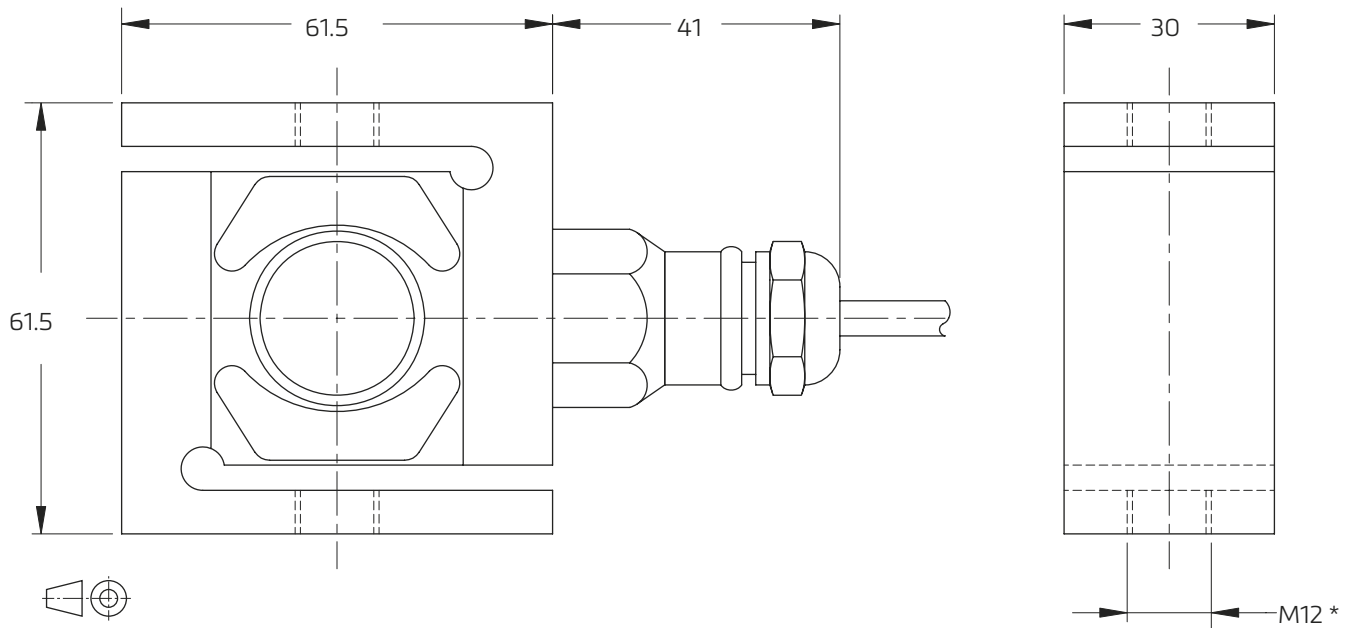

*Unified thread 1/2-20 UNF is available

wiring

The load cell is provided with a shielded, 4 conductor cable (AWG 24).

Cable jacket: polyurethane

Cable length: 6 m

Cable diameter: 5 mm

The shield is floating
(On request the shield can be connected to the load cell body)

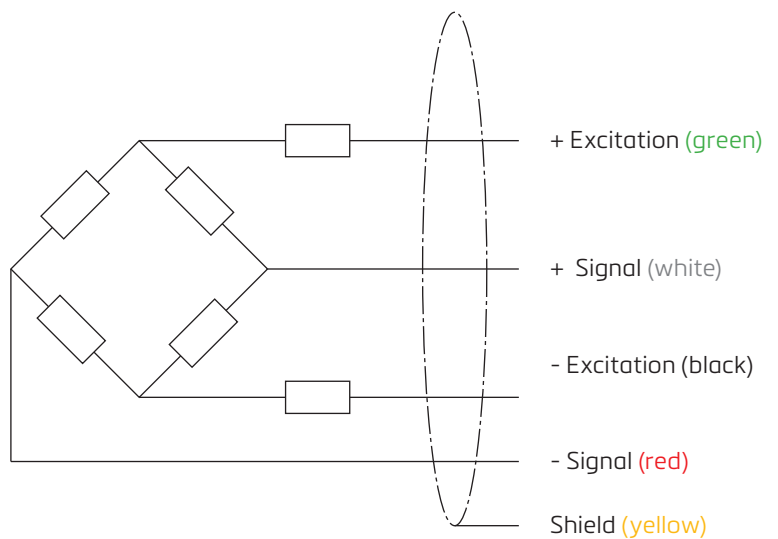

Specifications and dimensions are subject to change without notice.